

GSH 350-500

Heavy Duty Granulator

- Knives are adjusted outside of the machine
- Specially developed deflector wedge
- Wide choice of rotors
- Well thought out housing design
- Strong Welded Steel construction
- Oversized outboard bearings

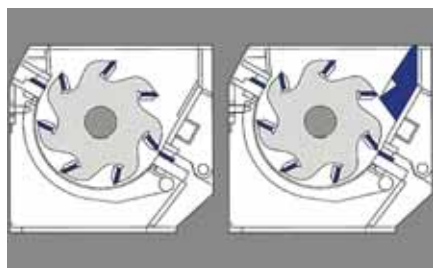

The easily removable deflector wedge acts as a third stator blade and can be used to adjust the aggressiveness of the rotor at the first cutting point.



The GSH granulators are available with different rotor options to fit different applications, all rotors feature the V-cut technology creating a high quality regrind.



The heavy duty bearings are separated from the cutting chamber to avoid lubricants entering the cutting chamber and bearing failure due to material contamination in the bearings.

General Description

The heavy duty granulators of the GSH 350 and 500 series offer a wide array of different rotor designs with widths ranging from 500 mm to 1000 mm with a diameter of 350 and 500 mm respectively. The completely welded heavy steel construction is designed to withstand the most demanding and universal applications. Rotor bearings, knife mounts and rotor shaft are oversized. The standard V-cut creates a high quality regrind with a very low percentage of fines in the output material. The removable third stator blade is acting as a deflector wedge and allows the machine to be quickly adjusted to different application scenarios. Other standard features include easily replaceable wear plates in the cutting chamber as well as outboard bearings reducing the risk of contamination.

Applications

The wide range of rotors and hopper styles allow the GSH machines to be tailored to almost every application in the plastic recycling field. The GSH 350 and 500 granulators are mainly used as central granulators for in house recycling applications to process thick walled parts in one step or as a second step granulator after a shredder to reach higher throughput rates. When used to grind light materials, such as bottles the throughput can be greatly increased with the addition of a ZERMA force feeding device. For abrasive, contaminated or highly filled materials the machines can be equipped with special wear protections, such as hard facing of the rotor and housing and key parts manufactured from highly wear resistant steels.



The Home of Size Reduction

GSH 350-500

Heavy Duty Granulator

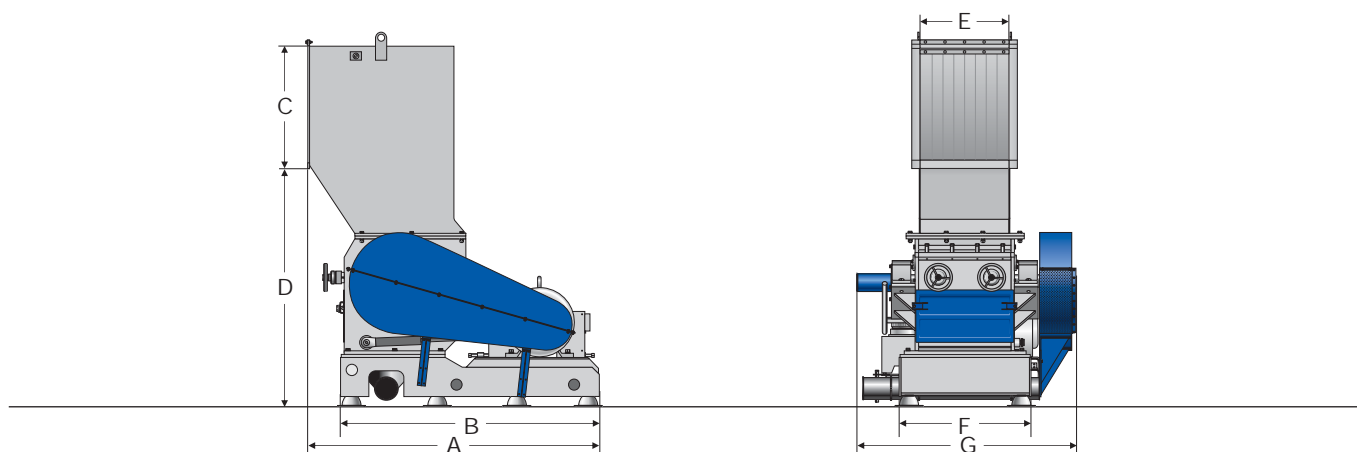

Technical Specifications and Dimensions

Model

Rotor diameter (mm)
Rotor width (mm)
Drive capacity (kW)
Rotor knives (rows)
Stator blades (rows)
Screen size (mm)
Effective working area (mm)
Weight approx (kg)

350/500

350
500
22
3 or 5
2 or 3
>6
460 x 516
1800

500/600

500
600
55
3 or 5
2 or 3
>6
636 x 590
3100

500/1000

500
1000
75
3 or 5
2 or 3
>6
985 x 590
4200

A (mm)

1820

2130

2320

B (mm)

1620

2020

2220

C (mm)

740

800

900

D (mm)

1610

1765

1870

E (mm)

515

635

985

F (mm)

775

1090

1540

G (mm)

1290

1570

1915

ZERMA MACHINERY & RECYCLING TECHNOLOGY CO. LTD.

5 Xinjie Rd Xinqiao Township Ind. Park

Songjiang · Shanghai · China

Phone : +86 21 57645573 · info@zerma.com

Technical modifications reserved / ver1.7 - 08.2015 / en

zerma.com

