

# GSP

## Pipe/Profile Granulator

- Knives are adjusted outside of the machine
- Specially developed deflector wedge
- Wide choice of rotors
- Well thought out housing design
- Strong Welded Steel construction
- Oversized outboard bearings



Rotor and stator knives are pre-set outside the machine prior to installation in a supplied fixture. This makes awkward adjustment inside the machine unnecessary.



The specially angled rotor automatically pulls the fed pipes or profiles into the cutting chamber, this design also regulates the amount of material.



The heavy duty bearings are separated from the cutting chamber to avoid lubricants entering the cutting chamber and bearing failure due to material contamination in the bearings.

### General Description

The Pipe and Profile Granulators of the GSP series are available in rotor widths of up to 1400mm and diameters ranging from 560 to 700 mm. The completely welded heavy steel cutting chamber is angled and fitted with an extended hopper to allow easy feeding of parts. The standard V-cut creates a high quality regrind with a very low percentage of fines in the output material. Other standard features include an hydraulically opened hopper for outboard bearings reducing the risk of contamination.

### Applications

Conventional granulators have substantial problems handling long pipes and profiles. To feed large and bulky parts in most cases cavities or platforms are needed. Therefore Zerma developed the GSP range. Thanks to the almost level feeding hopper, long pieces can be fed easily. While the machine is operating there is no risk of blocking, in case of congestion no more material will be accepted by the machine until the grinding chamber is empty and the machine will accept material again, and work continues.



The Home of Size Reduction

# GSP

## Pipe/profile Granulator

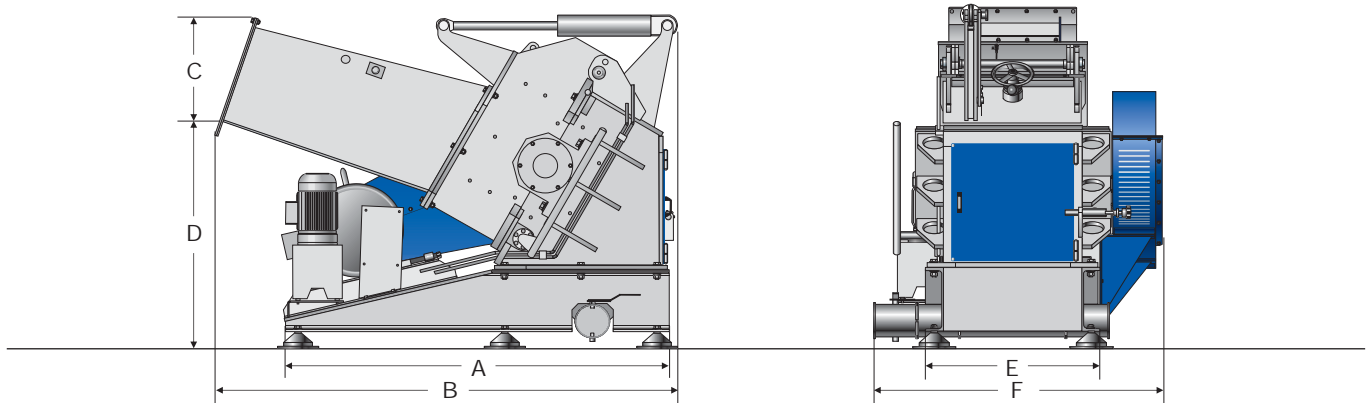

### Technical Specifications and Dimensions

Model	600/500	560/700	560/1000	700/1400
Rotor diameter (mm)	600	560	560	700
Rotor width (mm)	500	700	1000	1400
Drive capacity (kW)	45	55	75	90
Rotor knives (rows)	5	5	5	5
Stator blades (rows)	2	2	2	2
Screen size (mm)	>8	>8	>8	>8
Effective working area (mm)	440 x 530	290 x 740	290 x 1010	320 x 1440
Weight approx (kg)	4000	5000	6400	9000
A (mm)	1940	2290	2450	2420
B (mm)	2245	2400	220	2580
C (mm)	440	220	1250	300
D (mm)	1040	1250	1380	1255
E (mm)	940	1170	2060	1840
F (mm)	1350	1785		2400

ZERMA MACHINERY & RECYCLING TECHNOLOGY CO. LTD.

5 Xinjie Rd Xinqiao Township Ind. Park

Songjiang · Shanghai · China

Phone : +86 21 57645573 · info@zerma.com

Technical modifications reserved / ver1.7 - 08.2015 / en

zerma.com

