

# GSL 180

## Beside the Press Granulator

- Direct driven staggered rotor
- Special knife design makes adjustment unnecessary
- Easy access for maintenance and cleaning
- Slow rotor speed creates less noise and dust
- Easily customizable to suit different applications

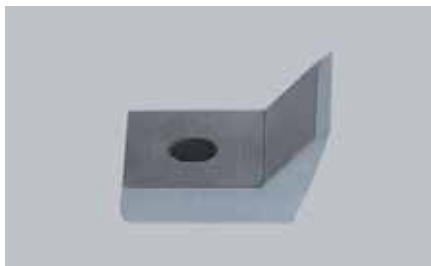

The curvature of the specially profiled rotor knives ensures a constant cutting radius after re-sharpening thus maintaining the original cutting gap. Awkward knife adjustment is no longer necessary.

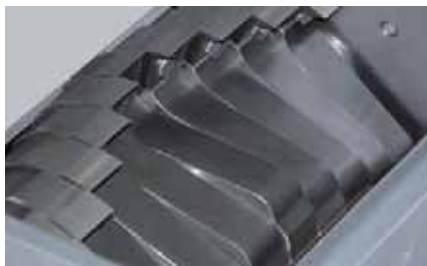

Staggered rotor blades creates an individual blade cut thus increasing the cutting torque. All of the machines in this series are therefore suitable for grinding more solid materials and thicker walled sprues.



The ZERMA Quick Snap System allows the lower front plate section to be easily removed for granulator cleaning. The lower front plate section is held in position by two sturdy lever clamps.

### General Description

The slow speed granulators in the GSL 180 range feature a staggered 180 mm diameter rotor with widths ranging from 180 to 430 mm. The rotor is directly driven by a geared motor. The low rotor speed reduces the noise level of the machine and creates less dust while grinding. The special design knives of the GSL series can be sharpened easily and do not need adjustment afterwards.

The material is fed via a sound absorbing feed hopper that can be tailored to fit various applications and feeding ways. Depending on the requirements the machines can be fitted with a wide variety of hoppers, they are mounted on either low or high level base frames with matching suction bins or bag filling adapters. Quick snap fasteners and hand screws make access to the machine for cleaning and maintenance fast and easy.

### Applications

The GSL slow speed granulators of the 180 series are mainly used in injection and blow molding processes as beside the press machines to grind runners and sprues. The resulting granules are then immediately reintroduced into the production process. The machines can be used for rejected products in the inline recycling process as well.

Different hopper and base frame designs make it possible to integrate the machine with most types of injection molding machines and robots.



The Home of Size Reduction

# GSL 180

Beside the Press Granulator

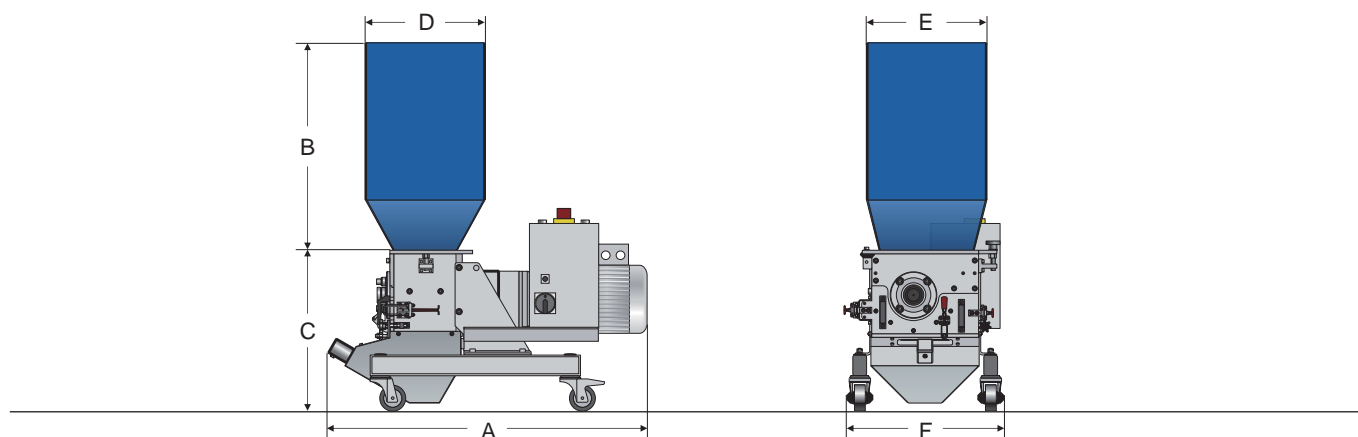

## Technical Specifications and Dimensions

Model	180/120	180/180	180/300	180/430
Rotor diameter (mm)	180	180	180	180
Rotor width (mm)	120	180	300	430
Rotor speed (rpm)	150	150	150	150
Drive capacity (kW)	2.2	3	4	4
Rotor knives (pcs)	12	18	30	45
Stator blades (rows)	2	2	2	2
Screen size (mm)	>5	>5	>5	>5
Weight approx (kg)	130	140	180	250
A (mm)	835	890	1100	1240
B (mm)	610	610	610	910
C (mm)	460	460	460	550
D (mm)	345	345	345	430
E (mm)	345	345	345	290
F (mm)	455	455	455	615

ZERMA MACHINERY & RECYCLING TECHNOLOGY CO. LTD.

5 Xinjie Rd Xinqiao Township Ind. Park

Songjiang · Shanghai · China

Phone : +86 21 57645573 · info@zerma.com

Technical modifications reserved / ver1.7 - 08.2015 / en

zerma.com

